

Montageanleitung Rollwagen

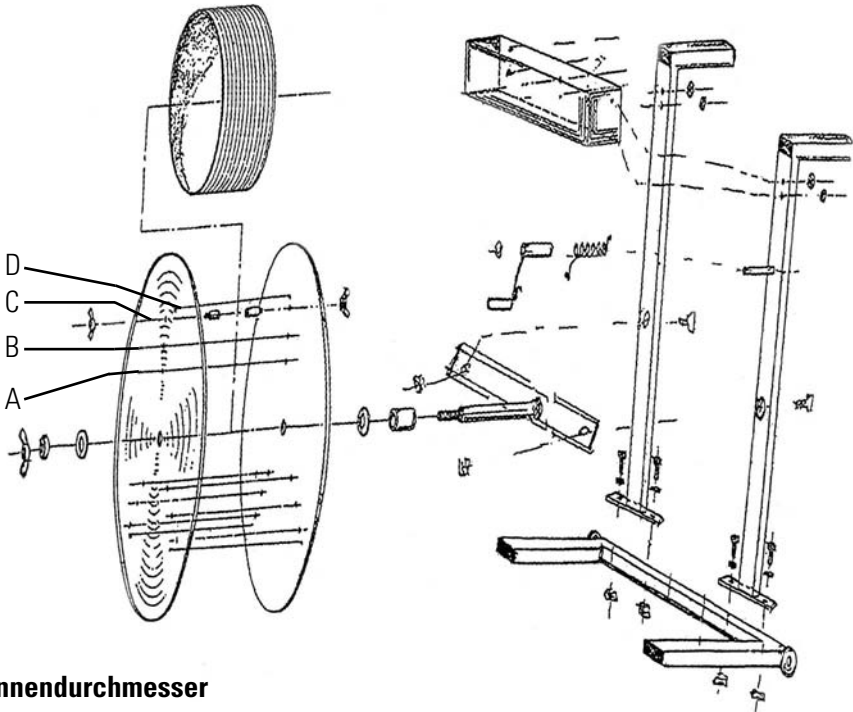

Innendurchmesser

- A= 200 mm
- B= 280 mm
- C= 400 mm
- D= 405 mm